

Welcome to Box Seat Baseball!

INTRO -

Brothers Tom and Bill Downing were veterans of table top baseball games, having played many of the top games on the market. While they enjoyed those games, they always felt something was missing and set about designing their own game. The result, Box Seat Baseball, captures the imagination and features the nuances that make baseball special.

The pitcher/hitter interaction, the focal point of real life baseball, is richly represented with unmatched depth and realism. A truly unique system that blends both hitter AND pitcher tendencies in each confrontation while accounting for a myriad of different variables that keep the gamer completely engaged. Throw in nuances like the heat tiring a starter early, the wind affecting deep flies, starting pitchers performance early and late in the game, hitter's performance with RISP, ground ball/fly ball tendencies along with pull/spray tendencies for hitters, to go with visualization of plays and variety of results on the base paths and in the field keep gamers coming back over and over for more!

This quick reference guide is intended to help rookies and veterans alike with the more common routines found in the Easy Play version of the game.

THE PLAYER CARDS

Let's take a look at a couple of stars from the 1970's and get an idea for how the player cards are layed out:

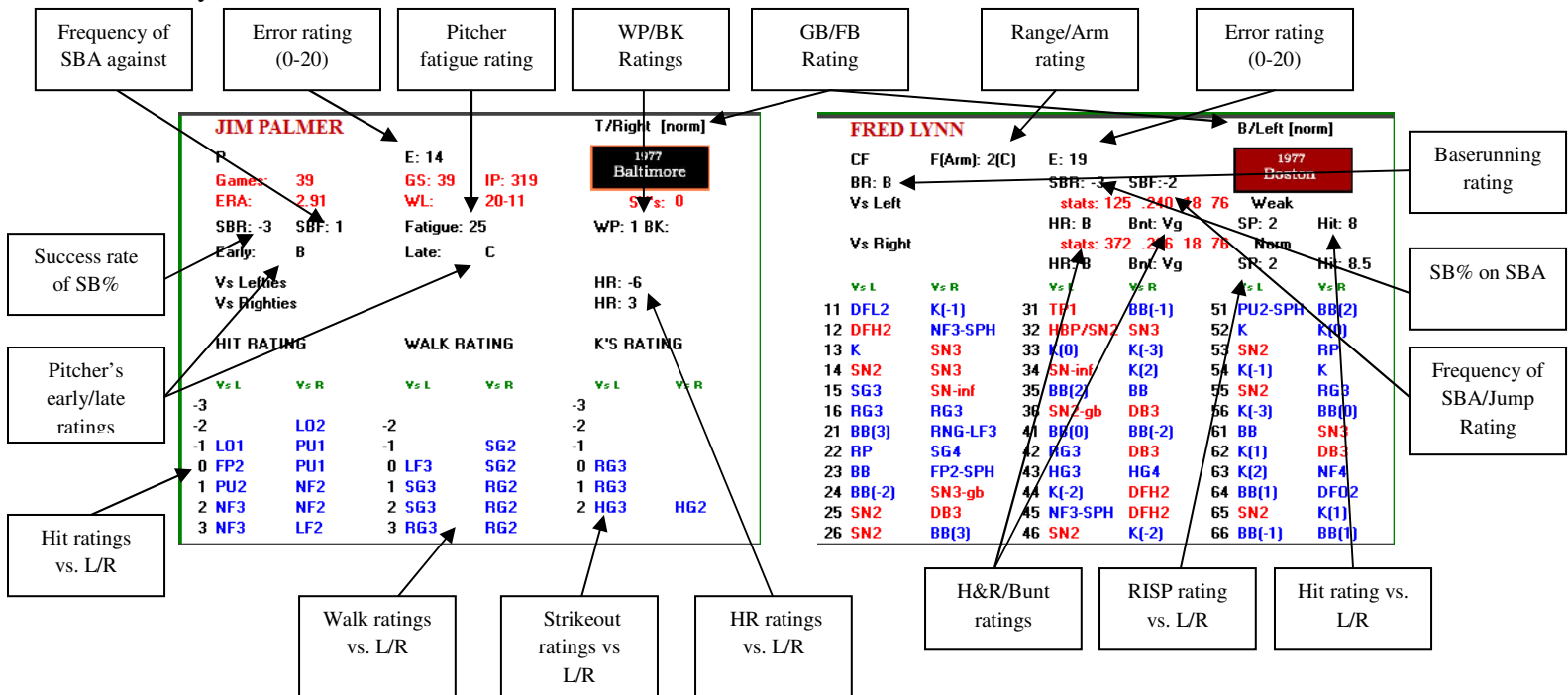

Easy Play Hit Routine

WILLIE MAYES B/ Right [fb] 1956
 New York (N)

CF F(Arm): 1(A) E: 16
 B/R: A+ SB/R: 1 SBF: 4

Vs LEFT: stats: 130 .315 36 84 Norm
 H/R: B Bnt: Pr SP: 1 Hit: 9.0

Vs RIGHT: stats: 448 .290 36 84 Power
 H/R: A Bnt: Pr SP: 1 Hit: 9.0

11	SN1	DFL1	31	TP1/DB2	SN1	51	DFH1	RP/+WP
12	PU1-SPH	BB	32	BB(3)	K(2)	52	BB(1)	DFO1
13	NF1	RG1	33	K(0)	SN1	53	LF1	SN-inf
14	SN1	LO1-SPH	34	BB(-1)	K(1)	54	BB(2)	SN1
15	K(-2)	K(0)	35	RG1	TP1/DB2	55	DB1	SN1
16	BB(-2)	K(-2)	36	SN1	DFH1	56	BB	PU1
21	RP/+WP	BB(0)	41	K(2)	BB(2)	61	DB1	DB1
22	SN1	DFH1	42	SN1	BB(-2)	62	K	K(-1)
23	DFH1	NF1	43	K(0)	BB(0)	63	RNG-SGT	HG1
24	K(-1)	RNG/LF1	44	SN1	BB(1)	64	BB	DFH1
25	SN-inf	K(-3)	45	BB(0)	BB	65	HG1	SN1
26	DB1	SN1	46	DFO1	BB(-1)	66	K(1)	SN1

DON NEWCOMBE T/ Right [norm] 1956
 Brooklyn

P E: 17
 Bats: Left Hit: Card

Games: 38 GS: 36 IP: 268
 ERA: 3.06 W/L: 27-7 SV's: 0

L1 Ftg: 29 L2 Ftg: 21 SBR: -2 SBF: 0
 Early: C Late: C WP: 2 PO/BK: Fr

Vs LEFTIES: HR: -3
 Vs RIGHTIES: HR: 3

HIT RATING		BB'S RATING		K'S RATING	
-3				-3	
-2	BTR/LO1	-2	SG2	-2	
-1	LO1	PU1	-1	LF3	SG2
0	PU2	PU1	0	SG3	RG2
1	PU2	NF2	1	SG3	RG2
2	NF3	NF2	2	RG3	RG2
3	NF3	LF2	3	RG3	RG2

The 2d6 & 1d10 are rolled resulting in a 53 and a 7. Looking at Mays card vs. R we find a RED SN-inf at the 53 position, or a possible infield single. Checking May's hit rating vs. R we find 9.0 and flip the FAC to check for the outcome.

On the FAC at the 9.0 position we find a (2)*D. This means that if it's the 1st inning or the 7th inning on and Newcombe is a D or worse for his EARLY/LATE rating we use May's result. If Newk is a C or better OR if it's the 2-7th inning we check Newk's hit rating vs. R at the (2) spot and find an NF2.

In this case, Newcombe wins the matchup because his EARLY rating is a C and we use the NF2 result. The NF2 becomes a normal fly out to left field (taken from the FAC on the right) with a runner on third having the option to try and score from 3rd. If the d10 had been a 0 we would check for an error on the fly ball using the FB: 15 error rating on the left FAC. Any fielder with an error rating of 14 or less would drop the fly for an error.

0.0 (2)	0.5 (2)	1.0 (1)	1.5 (1)	2.0 (1)
2.5 (1)	3.0 (0)	3.5 (0)	4.0 (0)	4.5 (1)
5.0 (0)	5.5 (1)	6.0 (1)	6.5 (2)*D	7.0 (1)
7.5 (2)*D	8.0 (2)*D	8.5 (3)*E	9.0 (2)*D	9.5 (3)*E
10.0 (3)*E	10.5 *A	11.0 (3)*E	11.5 *B	12.0 *A
12.5 *B	13.0 *A	13.5 *B	14.0 *B	14.5 Btr
15.0 Btr	15.5 Btr	16.0 Btr	16.5 Btr	17.0 Btr
17.5 Btr	18.0 Btr	18.5 Btr		

Hit or Out Range Check

Fld Rating "< 2"

OF CK

SNG: MP (pofm) DBL: Arm (Z)

GB: 20 FB: 15 POP: 15 HIT: 17 STL: 10

0 (+5)	1	2	3	4
HG/RG/SG	3B a+/b/1a0c	SS a+/b/1a0c	2B a/c/1a0c	2B a+/b/1a0c
LF/NF/SF	CF 32ma/3m/	LF 3/3m/	CF 32ma/3m/	CF 32ma/3m/
PU/LO	SS /2	SS /2		
FP	1B	3B		
DF	LF 32m1am	LF 32m1ma		
SN	LF-av-1	LF-aa-2	CF-hs-3	2B N
DB	LF-dtl-CO	CF-ilg-BB	CF-irg-BB	
TP	CF			

Singles Base Advance

Runner 1st		Scoring Position	
Rnr 1st	Rnr 2nd	Rnr 1st	Rnr 1st
1	2nd (2nd)	m (C>4th)	2nd (2nd)
2	B>m (B>m)	4th (4th)	A>3rd (B>3rd)
3	2nd (2nd)	m (m)	2nd (2nd)

Easy Play Range Check Routine

WILLIE MAYS						B/ Right [fb]	
CF	F(Arm): 1(A)	E: 16	1956				
B/R: A+	SB/R: 1	SFB: 4	New York (N)				
Vs LEFT:		stats: 130 .315 36 84	Norm				
H/R: B	Bnt: Pr	SP: 1	Hit: 9.0				
Vs RIGHT:		stats: 448 .290 36 84	Power				
H/R: A	Bnt: Pr	SP: 1	Hit: 9.0				
Vs L	Vs R	Vs L	Vs R	Vs L	Vs R		
11 SN1	DFL1	31 TP1/DB2	SN1	51 DFH1	RP/+WP		
12 PU1-SPH	BB	32 BB(3)	K(2)	52 BB(1)	DFO1		
13 NF1	RG1	33 K(0)	SN1	53 LF1	SN-inf		
14 SN1	LO1-SPH	34 BB(-1)	K(1)	54 BB(2)	SN1		
15 K(-2)	K(0)	35 RG1	TP1/DB2	55 DB1	SN1		
16 BB(-2)	K(-2)	36 SN1	DFH1	56 BB	PU1		
21 RP/+WP	BB(0)	41 K(2)	BB(2)	61 DB1	DB1		
22 SN1	DFH1	42 SN1	BB(-2)	62 K	K(-1)		
23 DFH1	NF1	43 K(-3)	BB(3)	63 RRG-SG1	HG1		
24 K(-1)	RRG-LF1	44 SN1	BB(1)	64 BB	DFH1		
25 SN-inf	K(-3)	45 BB(0)	BB	65 HC1	SN1		
26 DB1	SN1	46 DFO1	BB(-1)	66 K(1)	SN1		

CARL FURILLO						B/ Right [gb]	
RF	F(Arm): 4/4(C)	E: 17/20	1956				
B/R: C-	SB/R: -2	SFB: -2	Brooklyn				
Vs LEFT:		stats: 55 .327 21 83	Norm				
H/R: A	Bnt: Md	SP: -1	Hit: 10.5				
Vs RIGHT:		stats: 468 .284 21 83	Power				
H/R: A	Bnt: Md	SP: -1	Hit: 10.0				
Vs L	Vs R	Vs L	Vs R	Vs L	Vs R		
11 RG2	DFH1	31 SN2	RG1	51 PU1	K(-3)		
12 DB2	RP/+WP	32 BB(3)	SN1-gb	52 BB(1)	SG1		
13 DFH1	K(-2)	33 SN2	BB(1)	53 RG2	DFO1		
14 SN2-gb	SN1	34 SN2-gb	BB(2)	54 NF2	DFH1		
15 BB(-2)	DFL1	35 BB	BB(-2)	55 BB(0)	BB		
16 SN2	BB(3)	36 RRG-HG2	SN1	56 K(2)	DB1		
21 SN2	RG1	41 SN2	SN1	61 DB2	NF1		
22 K(0)	SN1	42 RP/+WP	BB(0)	62 BB(-1)	K(1)		
23 SN2-gb	SN1-gb	43 SN2	DB1	63 DFM1	BB(-1)		
24 BB	SN1	44 K(-2)	DB1	64 SN2-gb	HG1		
25 SG2	LF1	45 K(-1)	K(-1)	65 SN2	SN1-gb		
26 BB(-2)	K(0)	46 K(1)	SN1	66 BB	K(2)		

In this at bat the 2d6/1d10 roll comes up 61/3 which we find is a DB1 vs. R on May's card (DB is the symbol for Double). Once again, using May's hit rating vs. R of 9.0 we flip the FAC and check for a result. This time we find 'Rng' at the 9.0 spot, indicating a range check that will determine if the double occurs.

First, we must determine whose range is being challenged so we check the FAC on the right using the DB1 symbol and find Newcombe's right fielder Carl Furillo is being challenged. Furillo was a once a great fielder in his prime, is now a liability with the glove as in a 4 (worst rating) in RF.

Now that we have determined to whom the ball is hit to we flip another FAC (not shown) and check to see if the play is made. Here we find that only a fielder with a rating of 1 (the best) would make the play on this ball and the 'Say Hey Kid' has doubled off the wall in right!

Note: Range results can be altered by the ballpark (optional) using the green result.

0.0 (0)	0.5 (0)	1.0 Rng	1.5 (-1)	2.0 Rng
2.5 (-2)	3.0 Rng	3.5 (-3)	4.0 Rng	4.5 (-3)
5.0 Rng	5.5 (-3)	6.0 Rng	6.5 (-3)	7.0 Rng
7.5 (-3)	8.0 Rng	8.5 (-3)	9.0 Rng	9.5 (-3)
10.0 Rng	10.5 (-3)	11.0 Rng	11.5 (-3)	12.0 Rng
12.5 (-3)	13.0 Rng	13.5 (-3)	14.0 (-3)	14.5 (-2)
15.0 (-3)	15.5 (-2)	16.0 (-3)	16.5 (-2)	17.0 (-3)
17.5 (-2)	18.0 (-3)	18.5 (-2)		

Hit or Out Range Check				
Fld Rating "MP" (BP # 0)				
OF CK				
SNG: < 3 (Z)		DBL: < 3 (Z)		
GB: 9 FB: 0 POP: 2 HIT: 0 STL: 5				

+8 (NA)	1	2	3	4
	HG/RG/SG	2B 2c/a+/1a0	1B /a/1b0	1B /a/1b0
LF/NF/SE	LF 3/3m/	CF 32ma/3m/	CF 32ma/3m/	RF 32m/3m/
P/U/O	2B	SS		
FP	C	C		
DF	LF 32m1ma	RF 321ma		
SN	RF-av-1	RF-av-1	RF-bl-2	3B D
DB	RF-ctw-33	RF-btw-CC	RF-irg-BB	
TP	RF			

Singles Base Advance			
Runner 1st	Scoring Position		
Rnr 1st	Rnr 2nd	Rnr 1st	
1	A>3rd (B>3rd)	m (4th)	A>3rd (B>3rd)
2	B>3rd (3rd)	4th (4th)	B>3rd (3rd)

Easy Play Auto SB Routine

WILLIE MAYS B/ Right [fb]

1956
New York (N)

CF F(Arm): 1(A) E: 16 SBF: 4

B/R: A+ SBR: 1

Vs LEFT: stats: 130 .315 .36 .84 Norm Hit: 9.0
H/R: B Bnt: Pr SP: 1

Vs RIGHT: stats: 448 .290 .36 .84 Power Hit: 9.0
H/R: A Bnt: Pr SP: 1

Vs L	Vs R	Vs L	Vs R	Vs L	Vs R
11 SN1	DFL1	31 TP1/DB2	SN1	51 DFH1	RP/+WP
12 PU1-SPH	BB	32 BB(3)	K(2)	52 BB(1)	DFO1
13 NF1	RG1	33 K(0)	SN1	53 LF1	SN-inf
14 SN1	LO1-SPH	34 BB(-1)	K(1)	54 BB(2)	SN1
15 K(-2)	K(0)	35 RG1	TP1/DB2	55 DB1	SN1
16 BB(-2)	K(-2)	36 SN1	DFH1	56 BB	PU1
21 RP/+WP	BB(0)	41 K(2)	BB(2)	61 DB1	DB1
22 SN1	DFH1	42 SN1	BB(-2)	62 K	K(-1)
23 DFH1	NF1	43 K(-3)	BB(3)	63 RNG-SG1	HG1
24 K(-1)	RNG-LF1	44 SN1	BB(1)	64 BB	DFH1
25 SN-inf	K(-3)	45 BB(0)	BB	65 HG1	SN1
26 DB1	SN1	46 DFO1	BB(-1)	66 K(1)	SN1

DON NEWCOMBE T/ Right [norm]

1956
Brooklyn

P E: 17

Bats: Left Hit: Card

Games 38 GS: 36 IP: 268

ERA: 3.06 W/L: 27-7 SV's: 0

L1 Ftg: 29 L2 Ftg: 21 SBR: -2 SBF: 0

Early: C Late: C WP: 2 PO/RK: Fr

Vs LEFTIES: HR: -3
Vs RIGHTIES: HR: 3

HIT RATING		BB'S RATING		K'S RATING	
Vs L	Vs R	Vs L	Vs R	Vs L	Vs R
-3				-3	
-2	BTB/LO1	-2	SG2	-2	
-1	LO1	PU1	-1	LF3	SG2
0	PU2	PU1	0	SG3	RG2
1	PU2	NF2	1	SG3	RG2
2	NF3	NF2	2	RG3	RG2
3	NF3	LF2	3	RG3	RG2

Let's re-visit our hit routine example. This time Mays has led off an inning and reached base by rolling a 2d6 result of 45, which is a blue walk result vs. R. Since there is no suffix to the result Newcombe can't block it (looking at Newk's walk ratings vs R he blocks all walk results EXCEPT for those without a suffix).

To determine if Mays steals 2nd, we flip an FAC and refer to the first red number in the upper left hand corner. If after we have subtracted Newcombe's SBF rating from Mays' SBF rating the number is GREATER OR EQUAL to the FAC number, Mays attempts the steal. In this case, Mays is a SBF(4) and Newcombe a SBF(0) meaning that since the 4 is greater than the 0 found on the FAC, Mays takes off for second base.

To determine if Mays is safe, we combine Newcombe's SBR rating of (-2) with Dodger catcher Roy Campanella's arm rating of (C), which equates to a numerical value of 0 and divide by 2, resulting in a pitcher/catcher combination of -1. This is now applied to Mays SBR (1) and we will use an SBR(0) on the stolen base chart which means Mays is safe on a roll of 16-45.

0 (+5)	1	2	3	4
HG/RG/SG	3B*a+/b/1a0c	SS*a+/b/1a0c	2B a/c/1a0c	2B a+/b/1a0c
LF/NF/SF	CF 32ma/3m/	LF 3/3m/	CF 32ma/3m/	CF 32ma/3m/
PU/LO	SS /2	SS /2		
FP	1B	3B		
DF	LF 32m1am	LF 32m1ma		
SN	LF-av-1	LF-aa-2	CF-hs-3	2B N
DB	LF-dtl-CO	CF-irlg-BB	CF-irlg-BB	
TP	CF			

Singles Base Advance			
Runner 1st		Scoring Position	
Rnr 1st	Rnr 2nd	Rnr 1st	Rnr 2nd
1	2nd (2nd)	m (C>4th)	2nd (2nd)
2	B>m (B>m)	4th (4th)	A>3rd (B>3rd)
3	2nd (2nd)	m (m)	2nd (2nd)

Base Ratings (1996-2000)

(Pitcher's SBR Rating) / (2)

Catcher's Arm Rating / (2)

Classic Seasons (Pre 1996)

SBR	Safe Steal
Balk/PO	11-12
PutBk / PO	13
SB+PutBk E2	14 - 15
-5	16
-4.5	16 - 21
-4	16 - 23
-3.5	16 - 25
-3	16 - 31
-2.5	16 - 32
-2	16 - 34
-1.5	16 - 36
-1	16 - 41
-0.5	16 - 43
0	16 - 45
0.5	16 - 46
1	16 - 52
1.5	16 - 54
2	16 - 56
2.5	16 - 61
3	16 - 63

Stolen Base

- Check "Jump" block die even (on attempt steal). C
- Check on SB Att if "0E" Check on

Stolen Base

Balk/PO = Use Picket value for for stolen

PutBk/PO = Use Picket value for for stolen

SB+PutBk E2 = Auto SB

Auto SB

Steal of 3rd Adj: 1

Catcher Arm: A

Sacrifice Bunt Attempt (WBRCG)

Bunt Rating	Pr	Adj	Pr	Play Result
02	11 - 40	11 - 41	11 - 16	Sacrifice
03	11 - 34	02 - 45	11 - 34	Lead Off Check

Easy Play Error Check Routine

WILLIE MAYS B/ Right [fb]

CF F(Arm): 1(A) E: 16 1956
 B/R: A+ SB/R: 1 SBF: 4 New York (N)

Vs LEFT: stats: 130 .315 36 84 Norm
 H/R: B Bnt: Pr SP: 1 Hit: 9.0

Vs RIGHT: stats: 448 290 36 84 Power
 H/R: A Bnt: Pr SP: 1 Hit: 9.0

Vs L	Vs R	Vs L	Vs R	Vs L	Vs R
11 SN1	DFL1	31 TP1/DB2	SN1	51 DFH1	RP/+WP
12 PU1-SPH	BB	32 BB(3)	K(2)	52 BB(1)	DFO1
13 NF1	RG1	33 K(0)	SN1	53 LF1	SN-inf
14 SN1	LO1-SPH	34 BB(-1)	K(1)	54 BB(2)	SN1
15 K(-2)	K(0)	35 RG1	TP1/DB2	55 DB1	SN1
16 BB(-2)	K(-2)	36 SN1	DFH1	56 BB	PU1
21 RP/+WP	BB(0)	41 K(2)	BB(2)	61 DB1	DB1
22 SN1	DFH1	42 SN1	BB(-2)	62 K	K(-1)
23 DFH1	NF1	43 K(-3)	BB(3)	63 RNG-SG1	HG1
24 K(-1)	RNG-LF1	44 SN1	BB(1)	64 BB	DFH1
25 SN-inf	K(-3)	45 BB(0)	BB	65 HG1	SN1
26 DB1	SN1	46 DFO1	BB(-1)	66 K(1)	SN1

JIM GILLIAM B/ Both [norm]

2B/LF F(Arm): 3(3)(A) E: 16/18 DP: 0 1956
 B/R: A+ SB/R: 0 SBF: 0 Brooklyn

Vs LEFT: stats: 62 .210 6 43 Weak
 H/R: A Bnt: Md SP: 1 Hit: 6.0

Vs RIGHT: stats: 532 .310 6 43 Weak
 H/R: A Bnt: Md SP: 1 Hit: 10.0

Vs L	Vs R	Vs L	Vs R	Vs L	Vs R
11 SN2-gb	SN2/HBP	31 RP/+WP	SN2	51 DFL1	K(2)
12 RNG-SG2	RG3	32 SN2	RP/+WP	52 SN-inf	SN2-gb
13 HG2	SN2	33 K(1)	K(-1)	53 RG2	SN-inf
14 BB(2)	SN-inf	34 SN2	BB(1)	54 SN2	SN2
15 SN2	K(0)	35 K(-2)	SN2	55 BB(3)	BB(-1)
16 K(2)	SN2	36 BB(1)	RG3	56 SN2	BB(3)
21 NF2	FP2-SPH	41 BB(-1)	SN2	61 DFH1	BB(-2)
22 BB(-2)	BB	42 SG2	K(-2)	62 DB2	HG3
23 DB2	BB(2)	43 BB	BB	63 K(-1)	BB(0)
24 RG2	DB2/TP1	44 BB	NF3	64 NF2	DB2
25 PU1-SPH	BB	45 BB(0)	K(1)	65 BB	DFL2
26 RG2	SG3	46 BB	SN2	66 K(0)	SN2

In this at bat Mays rolls a 2d6/1d10 result of 63/0. This results in an HG1, or a hard ground out (often a double play). The ZERO on the d10 also tells us an error check will be in order.

We flip the FAC to see who the HG1 is hit to and find Dodger 2B Jim Gilliam is the fielder. If the d10 had not been a ZERO this would just be a ground out (or a double play if a runner was on first, despite Mays' A+ baserunning rating!). Instead, we need to do a quick check of the left FAC for the minimum error rating on a GB required to NOT make an error; we find a 9 and compare it to Gilliam's error rating of 16 and he's handled the tough smash and made the out. If Gilliam's error rating was < 9 an error would occur. We would re-roll the d10 and consult the infield error description chart to determine how the error was made and where Mays ends up.

0.0 (0)	0.5 (0)	1.0 Rng	1.5 (-1)	2.0 Rng
2.5 (-2)	3.0 Rng	3.5 (-3)	4.0 Rng	4.5 (-3)
5.0 Rng	5.5 (-3)	6.0 Rng	6.5 (-3)	7.0 Rng
7.5 (-3)	8.0 Rng	8.5 (-3)	9.0 Rng	9.5 (-3)
10.0 Rng	10.5 (-3)	11.0 Rng	11.5 (-3)	12.0 Rng
12.5 (-3)	13.0 Rng	13.5 (-3)	14.0 (-3)	14.5 (-2)
15.0 (-3)	15.5 (-2)	16.0 (-3)	16.5 (-2)	17.0 (-3)
17.5 (-2)	18.0 (-3)	18.5 (-2)		

Hit or Out Range Check

Fld Rating "MP" (BP # 0)

OF CK

SNG: < 3 (Z) DBL: < 3 (Z)

GB: 9 FB: 0 POP: 2 HIT: 0 STL: 5

+8 (NA)	1	2	3	4
HG/RG/SG	2B 2c/a+/1a0	1B /a/1b0	1B /a/1b0	2B 2c/a/1a0
LF/NF/SF	LF 3/3m/	CF 32ma/3m/	CF 32ma/3m/	RF 32m/3m/
PU/L	2B	SS		
FP	C	C		
DF	LF 32m1ma	RF 321ma		
SN	RF-av-1	RF-av-1	RF-bl-2	3B D
DB	RF-ctw-33	RF-btw-CC	RF-irg-BB	
TP	RF			

Singles Base Advance

	Runner 1st	Scoring Position
	Rnr 1st	Rnr 2nd Rnr 1st
1	A>3rd (B>3rd)	m (4th) A>3rd (B>3rd)
2	B>3rd (3rd)	4th (4th) B>3rd (3rd)